



EPS DENSIFIERS

All Electro-Mechanical Series EM-EPS-8
Pre-Breaker/Compaction System

MEANS
QUALITY

the green eps densification solution

Reduce Your
EPS Waste
By Up To
50 to 1



Reduce Your
Landfill Cost
RECYCLE!



Model: EM-EPS-8-1624-9.5

Optimize EPS Recycling & Transportation Cost • • •

Make the all electro-mechanical Komar Densifier part of your over-all corporate "Green" solution for EPS waste. With our offering of select sizes of pre-breakers and compactors, we can provide the most economical solutions to reduce your EPS materials to a size that can be efficiently compacted into easy to handle logs. The compaction screw removes the air and the memory from the EPS material creating a solid log of polystyrene with densities of 20 to 23 lbs. per cubic foot, achieving up to a 50 to 1 reduction. The extreme volume reduction accomplished in this fashion provides monumental savings in handling, floor space, transportation and disposal cost.

Benefits:

- Maximize EPS reduction
- Recycle valuable resources
- Reduce storage
- Reduce disposal cost
- Reduce transportation
- All electric (no hydraulics or pneumatics)
- Minimal electrical & human resources required
- Reduce operating & maintenance cost
- Feed by hand or conveyor



Manual or Conveyor
Feed

Processed Logs ready for
the recycler, approx. 1000 lbs.
per pallet load ready to ship.



KOMAR INDUSTRIES, INC.
4425 Marketing Place
Groveport, Ohio 43125



E-mail: info@komarindustries.com
Web: www.komarindustries.com
TEL: (614) 836-2366

All Electro-Mechanical Series EM-EPS-8 Pre-Breaker/Compaction System

the green eps densification solution

Technical Data:

- Length 90 3/8"
- Width 42 3/4"
- Height 82"
- Weight 3,000 lbs.
- Hopper Feed:
24" x 24" x 62 3/8"
- Power Required:
480 VAC, 3 PH. 60 HZ.

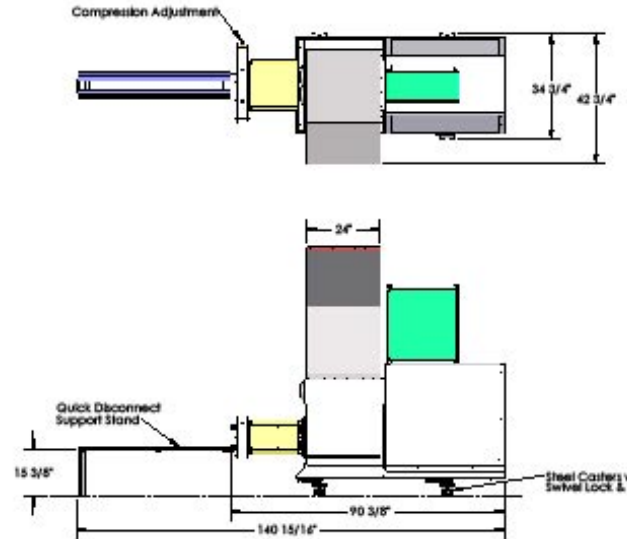
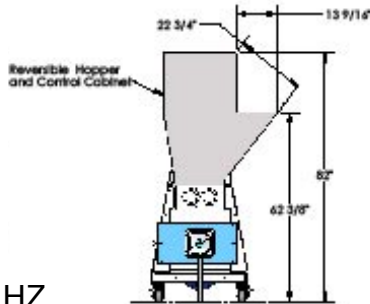

Technical Data:

Models	Log Size	Log Density	Capacity	Charge Opening	HP Total
EM-EPS-8-1624-9.5	8" x 8"	22 to 25 lbs/ft ³	100 to 125 lbs/Hr.	24"W x 16"L	9.5
EP-EPS-8-2424-12.5	8" x 8"	22 to 25 lbs/ft ³	100 to 150 lbs/Hr.	24"W x 24"L	12.5
EM-EPS-8-2448-15	8" x 8"	22 to 25 lbs/ft ³	100 to 200 lbs/Hr.	24"W x 48"L	15

EPS Markets:

Komar Industries has developed a line of all electro-mechanical EPS Densifiers for volumes from 100 lbs. per hour to 1000 lbs. per hour, producing truckloads of 40,000 lbs. for optimum efficiency. The EM-EPS-8 series of densifiers are ideally suited for:

- Wholesale Centers
- Furniture Distributors
- RV Manufacturers
- Appliance Distributors
- Consumer Electronic & Computer Distributors
- Food Distributors
- Hardware Centers
- Manufacturers
- Pharmaceuticals

Electrical Features:

- UL Type 4 Electrical Enclosure
- 110 VAC Control Transformer
- Allen Bradley PLC
- ITC:
 - Key Lock Switch
 - "E" Stop" Button
 - "Auto" Light Push Button
 - "Reset" Button
 - "Motor Overload" Light
- Automatic No Feed Shut Down
- Pre-breaker Digital Read Out Meter
- Feed Compactor Digital Read Out Meter
- Hour Meter