



Recycling Equipment, Inc.

Dump & Run Shredders

MODELS HD-30-30, HD-36-40, HD-36-50, HD-48-60,
HD-60-75, HD-60-100, HD-60-150, HD-72-200

PROCESSING OF:

Plastics
PVC
Wood Scrap
Leather
Medical Waste
Packing Materials
Synthetic Fiber
Carpet
Doors & Window Frames
Electronics
Cardboard & Paper Files
Fiberglass

APPLICATIONS & INDUSTRIES

Recovery Facilities
Plastics Product Manufacturing
Fiber Glass Manufacturing
Hospitals
Warehouses
Electronic Manufacturing
Pallet Producers
Furniture Manufacturers
Financial Institutions
Energy Recovery Systems



REI engineers, designs, manufactures and supports a series of "Dump and Run" Low RPM Rotary Industrial Shredders and Grinders for the most demanding material size reduction applications. These types of shredders allow the user to dump large quantities of scrap into the charge chamber at one time and walk away.

There are endless possibilities. REI has provided effective solutions for a wide array of shredding applications from wood pallets to e-scrap, from tires to medical waste and from books to confidential documents. To permit firsthand solution validation, we are able to perform throughput and consistency testing and analysis of your materials.

Our shredders and grinders offer a superior design, PLC controls, high energy efficiency motors, easy maintenance and a preventive maintenance program that is backed by our service repair team.

INPUT

OUTPUT

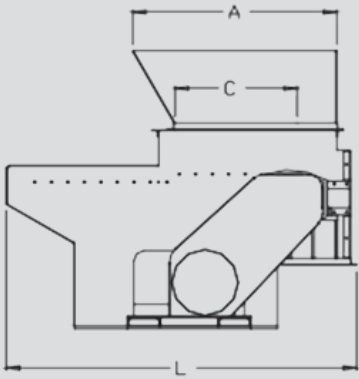

To eliminate material "bridging" REI incorporates a ram assist that is integrated with the cutting rotor controls. The rams sense the amount of pressure and duration of force to aid the cutter knives to grasp the material efficiently.



Sizing Screens can be sized from 3/8" to 3" for consistent particle sizes in a single pass. Attached to the cutting rotor are replaceable, precision fit, CNC machined KNIVES. They are heat treated for durability and six time indexable.

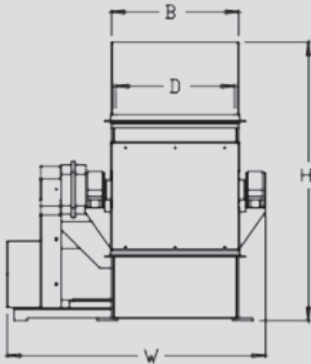

PERFORMANCE SPECIFICATIONS	HD-30-30	HD-36-40	HD-36-50	HD-48-60	HD-60-75	HD-60-100	HD-60-150	HD-72-200
Drive HP	30	40	50	60	75	100	125	200
Voltage (V/PH/Hz)	460/3/60	460/3/60	460/3/60	460/3/60	460/3/60	460/3/60	460/3/60	460/3/60
Rotor Diameter (in)	12	14	14	16	16	16 or 18	18 or 24	18 or 24
RPM	90-200	90-200	90-200	90-200	90-200	90-200	90-200	90-200
# of Cutting Disks	38	42	42	66	99	99	99	123
Sizing Screen Openings	1/2 to 5	1/2 to 5	1/2 to 5	1/2 to 5	1/2 to 5	1/2 to 5	1/2 to 5	1/2 to 5
Hopper Opening (AxB)	60 x 30	60 x 30	72 x 36	72 x 48	96 x 60	96 x 60	120 x 60	144 x 72
Charge Opening (CxH)	40 x 30	42 x 36	42 x 36	50 x 48	62 x 60	62 x 60	72 x 60	96 x 72
Hopper Volume (Yds)	1.5	1.8	2	2.5	3.5	3.5	4.5	6
Dimensions (LxWxH)	72 x 60 x 72	72 x 66 x 72	72 x 66 x 72	96 x 88 x 96	96 x 90 x 96	96 x 90 x 96	120 x 96 x 96	144 x 120 x 110
Weight of Shredder	5,200	6,200	6,800	7,800	9,600	11,500	16,500	22,500

Hydraulic cylinder driven RAM provides precision feed of scrap to cutting rotor PLC controls continuously adjust different load variables to maximize processing efficiency. Designed with replaceable UHMW guides to eliminate metal to metal contact.

Designed with replaceable UHMW guides to eliminate metal to metal contact.

Banded BELT DRIVE transfers power from motor to the gearbox.

FLUID COUPLINGS for soft, cushioned starts, mechanical protection and lower energy consumption.

High efficiency, hostile duty drive MOTORS.

Oversized class 3, shaft-mounted, speed reduction GEARBOX rated with a 2.2 service factor.

Large customizable HOPPERS with 2 to 1+ cubic yard capacities.

Solid steel CUTTING ROTOR is CNC machined and has a Limited Lifetime Warranty. Several sizes are available depending on the application.

Attached to the cutting rotor are replaceable, precision fit, CNC machined KNIVES. They are heat treated for durability and six times indexable.

CNC machined, heat treated COUNTER KNIVES can be rotated twice before replacement and ensure a close tolerance profile.

SCREEN can be sized from 3/8" to 3" for consistent particle sized in a single pass.

External mounted, heavy duty, self-aligning spherical ROLLER BEARINGS support the rotor.